

2026

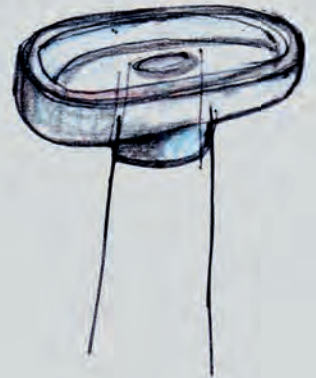
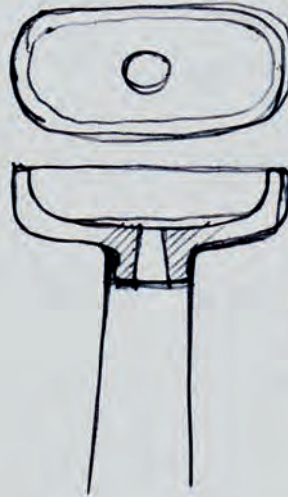
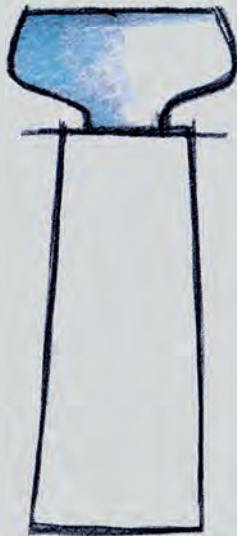

➔ **FLAMINIA.**

La continua ricerca estetica che contraddistingue il brand si traduce in nuove prospettive progettuali e inedite proposte cromatiche.

La ricca gamma di colori si amplia con tre nuove colorazioni lucide – Miele, Castagno e Tundra – ispirate alle tonalità della natura.

Quest'anno il lavabo **Miniwash**, disegnato da Giulio Cappellini, celebra i suoi vent'anni di produzione. Per l'occasione, l'azienda presenta una *special edition* numerata e firmata, proposta nella brillante tonalità Arancio Segnale.

Il 2026 segna inoltre l'ingresso di un nuovo protagonista del design nella grande famiglia Flaminia: Giulio Iacchetti, designer rigoroso, capace di rispettare e interpretare al meglio la materia. Dalla sua visione nasce **Hasu**, una linea di lavabi dalle forme morbide e slanciate, in equilibrio tra essenzialità e ricerca formale.

Prosegue così il percorso di Flaminia, tra innovazione e continuità, nella costante esplorazione di forme e colori.

The continuous aesthetic research that defines the brand takes shape in new design perspectives and original chromatic proposals.

The already extensive colour range is enriched with three new glossy finishes – Miele, Castagno and Tundra – inspired by the tones of nature.

*This year, the **Miniwash** basin, designed by Giulio Cappellini, celebrates twenty years of production. To mark the occasion, the company presents a numbered and signed special edition, offered in the vibrant Arancio Segnale finish.*

*2026 also marks the arrival of a new design protagonist within the Flaminia family: Giulio Iacchetti, a rigorous designer capable of respecting and interpreting the material at its best. From his vision comes **Hasu**, a collection of basins with soft, slender forms, balancing essentiality and formal research.*

Flaminia thus continues its journey between innovation and continuity, in a constant exploration of shapes and colours.

 **FLAMINIA.**

La *palette* Flaminia si apre a nuove suggestioni cromatiche che arricchiscono la finitura lucida con tre avvolgenti *nuancés* che rimandano al mondo naturale: il caldo e luminoso giallo **Miele**, l'intenso marrone **Castagno** e il sofisticato verde **Tundra**.

*The Flaminia palette opens up to new chromatic suggestions, enriching the glossy finish with three enveloping hues inspired by the natural world: the warm, luminous yellow **Miele**, the rich brown **Castagno**, and the sophisticated green **Tundra**.*



COLORS
2026

MIELE

CASTAGNO

TUNDRA



La famiglia di lavabi **Hasu**, disegnata da Giulio Iacchetti, prende ispirazione dal “fiore di loto”, simbolo di purezza per la sua capacità di sbocciare immacolato dalla terra. Questo riferimento si traduce in un oggetto che si innalza sul piano a partire da una base d’appoggio particolarmente ridotta, evocando il bocciolo del loto. Nella versione su colonna, la *silhouette* si slancia ulteriormente, trasformando il lavabo in un elemento architettonico di grande personalità.

Il lavabo è disponibile in due varianti – rotonda, con diametro di 44 cm, e ovale, lunga 58 cm – installabili da appoggio o su una colonna rastremata.

Sia il lavabo che la colonna sono proposti nei nuovi colori Castagno, Miele e Tundra, oltre che in tutte le finiture lucide e opache Flaminia. Hasu offre un’ampia possibilità di combinazioni, consentendo un elevato livello di personalizzazione.

*The **Hasu** washbasin family, designed by Giulio Iacchetti, draws inspiration from the “lotus flower”, a symbol of purity for its ability to emerge immaculate from the earth. This reference is translated into a design that rises from the surface on an exceptionally reduced base, evoking the lotus bud. In the pedestal version, the silhouette becomes even more slender, transforming the basin into a distinctive architectural element.*

The basin is available in two versions – round, with a diameter of 44 cm, and oval, 58 cm long – suitable for countertop installation or paired with a tapered pedestal.

Both basin and pedestal are offered in the new Castagno, Miele and Tundra colours, as well as in all glossy and matte finishes from the Flaminia palette. Hasu offers a wide range of combinations, ensuring a high level of customization.

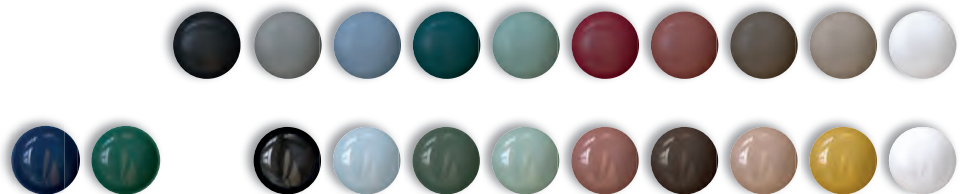



HASU

Giulio lacchetti

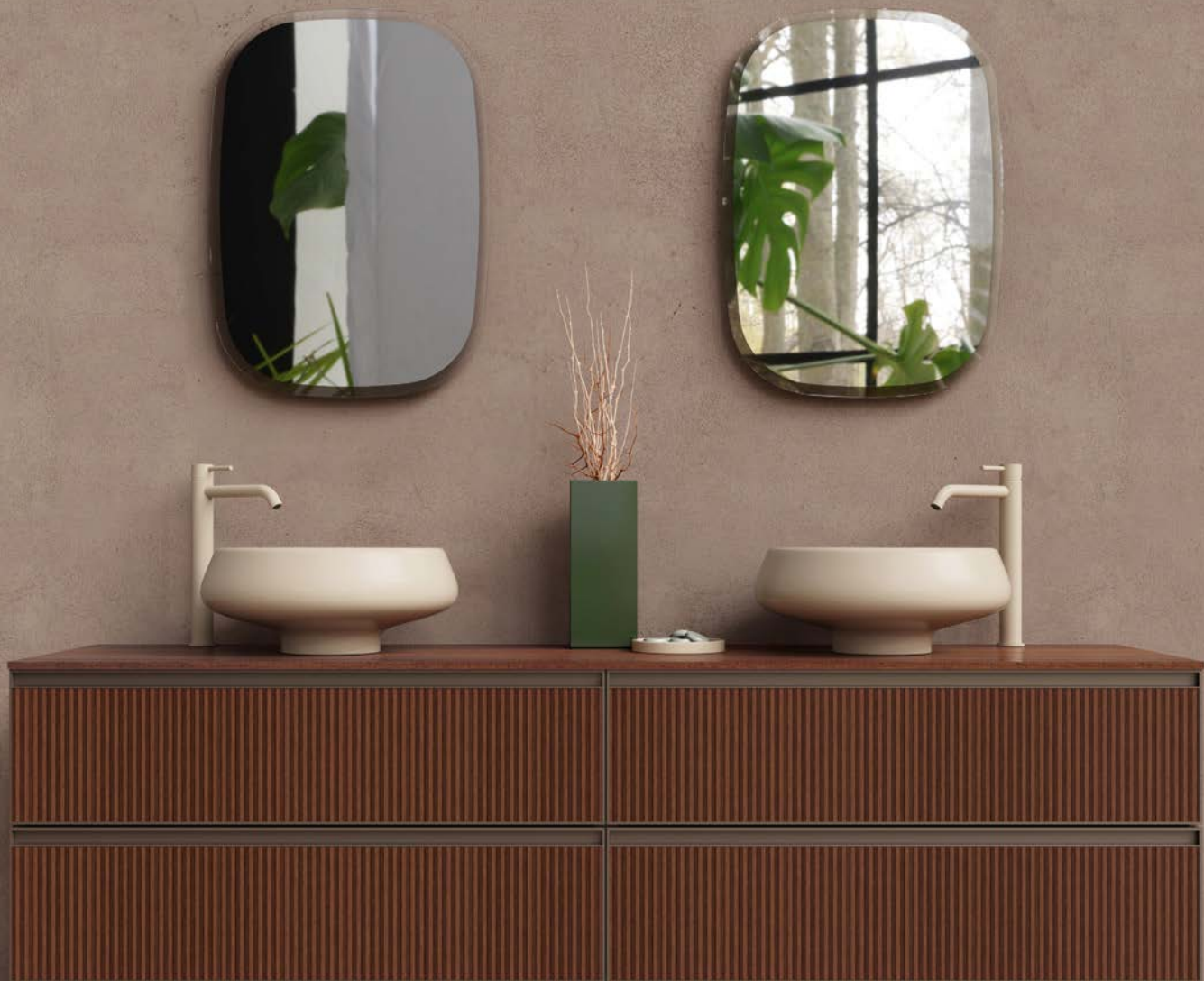

Hasu 44 _ Argilla
art. HS44AARG - ø 44 x h 18 cm

HASU 44

Giulio Iacchetti

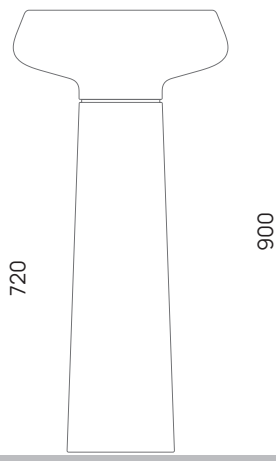
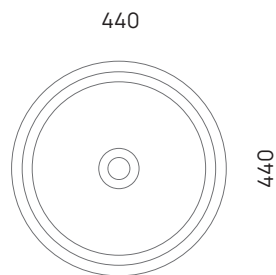

Hasu 44 _ Tundra + Miele
art. HS44ATU - ø 44 x h 18 cm
art. HSCOLMI - ø 23 x h 72 cm

HASU 58

Giulio Iacchetti



Hasu 58 _ Cenere
art. HS58ACEN - 58 x 44 x h 18 cm
art. HSCOLCEN - ø 23 x h 72 cm

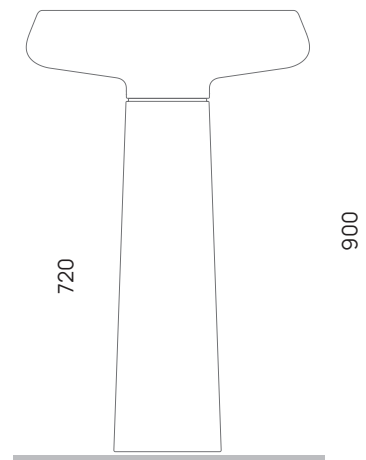
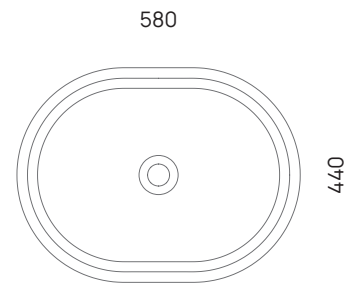



Hasu 58 _ Castagno
art. HS58ACA - 58 x 44 x h 18 cm

MIELE
+
TUNDRA



TOPAZIO
+
NUVOLA

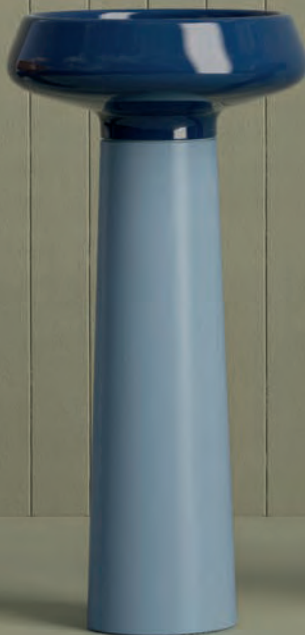

ARGILLA
+
CASTAGNO



TUNDRA
+
FANGO

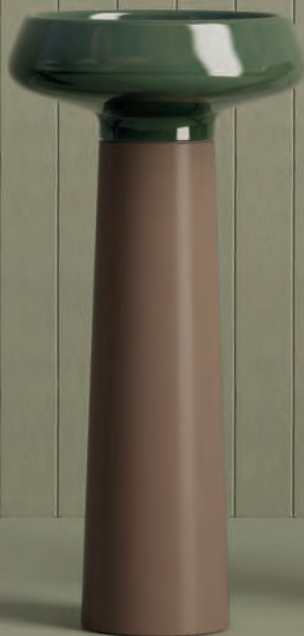

CASTAGNO
+
MIELE



AVANA
+
UVA



MINIWASH

SPECIAL EDITION

Giulio Cappellini



Miniwash 40 _ Arancio Segnale
art. MWL40AS - 40 x 40 x h 13 cm

Presentato in una vibrante tonalità Arancio Segnale, il lavabo **Miniwash** di Giulio Cappellini è proposto in una *special edition*, numerata e firmata dal designer, che ne celebra il ventesimo anniversario di produzione: un omaggio a un oggetto iconico che ha segnato la storia del brand.

*Presented in a vibrant Arancio Segnale finish, the **Miniwash** washbasin by Giulio Cappellini is offered in a numbered and signed special edition by the designer, celebrating its twentieth anniversary of production: a tribute to an iconic object that has marked the brand's history.*



ARANCIO
SEGNALE



NORMA

Elena Salmistraro



Norma _ Smeraldo
art. NA70CSME - 70 x 50 x h 94,5 cm

Il lavabo free standing **Norma**, dalla forte presenza e dall'importante impatto estetico, è caratterizzato da forme morbide e plastiche: una colonna a cilindro sostiene una conca che poggia su un comodo piano. L'inserimento di un piano d'appoggio in questa tipologia di lavabi rappresenta una significativa innovazione a livello funzionale. Norma, disegnato da **Elena Salmistraro**, è realizzato in vari colori. Un lavabo a colonna che da solo diventa protagonista assoluto dell'ambiente bagno.

*The **Norma** freestanding washbasin stands out for its strong presence and striking aesthetic impact, defined by soft, sculptural forms: a cylindrical column supports a basin resting on a practical integrated surface. The introduction of a support shelf in this type of washbasin represents a significant functional innovation.*

*Designed by **Elena Salmistraro**, Norma is available in a variety of colours. A pedestal basin that becomes the undisputed focal point of the bathroom space.*

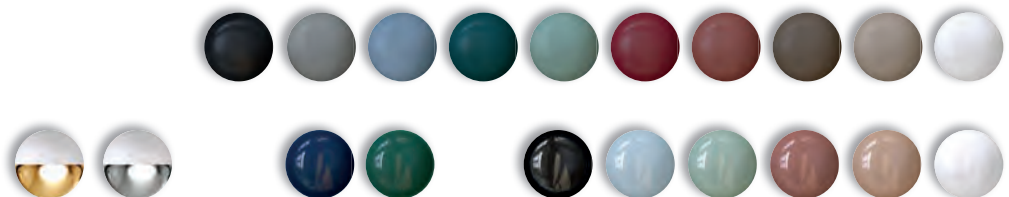



Norma _ Latte
art. NA70CLAT - 70 x 50 x h 94,5 cm

NORMA

Elena Salmistraro

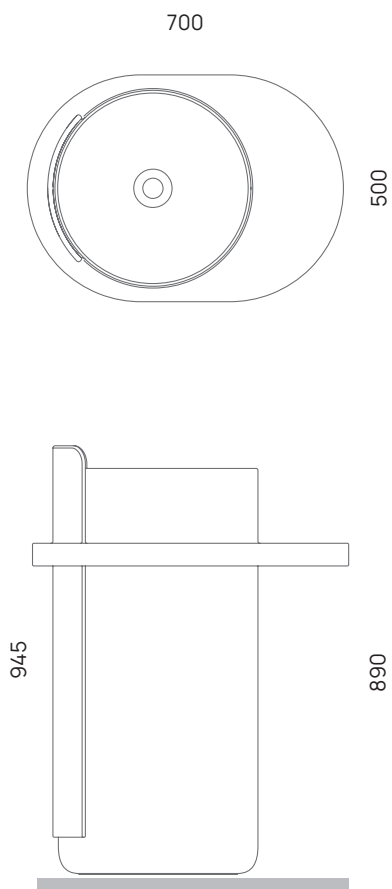

Norma _ Terracotta
art. NA70CTC - 70 x 50 x h 94,5 cm

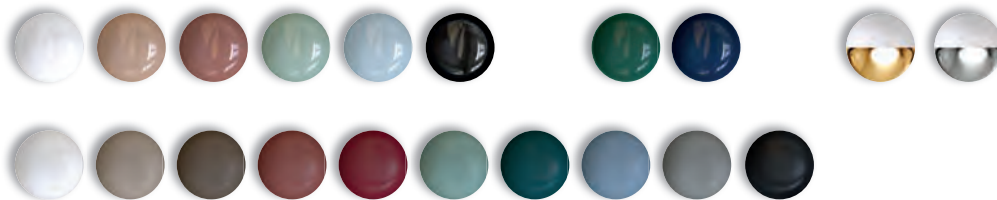

Settecento Cut _ Argilla
art. SECUTARG - ø 44 x h 16 cm

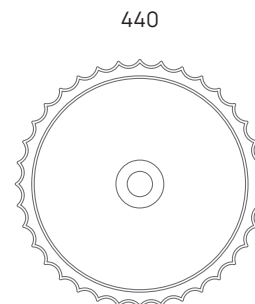

La fortunata famiglia di lavabi **Settecento**, firmata da Giulio Cappellini, si arricchisce di un nuovo elemento da appoggio: **Settecento Cut**, una sezione del lavabo freestanding **Monosettecento**.

Il lavabo è proposto in una gamma di colori vibranti e sofisticati, sia opachi che lucidi, che ne enfatizzano la tridimensionalità, confermando l'eccellenza produttiva di Flaminia.

Questa collezione, dalle forme classiche e tondeggianti, si ispira alle acquasantiere delle chiese barocche del Settecento.

*The successful **Settecento** washbasin family, designed by Giulio Cappellini, is enriched with a new countertop element: **Settecento Cut**, a section of the **Monosettecento** freestanding basin.*

The washbasin is available in a range of vibrant and sophisticated colours, both matte and glossy, enhancing its three-dimensionality and showcasing Flaminia's manufacturing excellence. With its classic, rounded shapes, the collection draws inspiration from the holy water fonts of 18th-century Baroque churches.

SETTECENTO CUT

Giulio Cappellini

Settecento Cut _ Topazio
art. SECUTTOP - ø 44 x h 16 cm

IL NUOVO CONFIGURATORE BAGNO: DESIGN E TECNOLOGIA A PORTATA DI CLIC

THE NEW BATHROOM CONFIGURATOR:
DESIGN AND TECHNOLOGY AT YOUR FINGERTIPS

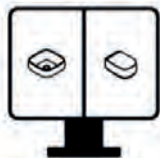

CONFIGURAZIONE SIMULTANEA
SIMULTANEOUS CONFIGURATION

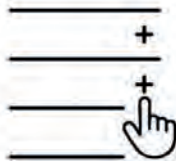

SCELTA GUIDATA
GUIDED SELECTION



REALTÀ AUMENTATA
AUGMENTED REALITY



DISTINTA SCARICABILE
DOWNLOADABLE LIST

Da sempre sinonimo di innovazione per l'ambiente bagno, Flaminia continua a guidare il cambiamento con uno strumento dedicato a privati, progettisti e rivenditori: il configuratore online per il bagno.

Pensato per offrire un'esperienza d'acquisto coinvolgente, intuitiva e personalizzata, consente con pochi clic di arredare il proprio bagno con i prodotti del marchio, combinandoli in tempo reale per valutarne l'effetto d'insieme. Il sistema mostra due viste separate, una per l'area lavabo e una per quella dei sanitari, permettendo così di ottenere una visione completa e coerente dell'ambiente. La navigazione è guidata passo dopo passo: si seleziona la collezione, poi il modello e il colore, infine si completa la composizione con rubinetteria e accessori. Una delle novità più interessanti è la personalizzazione simultanea delle due zone principali del bagno, ma il vero punto di forza è rappresentato dalla possibilità di visualizzare il risultato in realtà aumentata. Dopo aver configurato i prodotti, basta uno smartphone per vedere l'ambiente configurato prendere forma direttamente nel proprio spazio, ovunque ci si trovi. Una funzione utile e divertente che permette al cliente di scegliere con maggiore consapevolezza, rendendo ogni decisione più concreta e ragionata. Alla fine del processo si può scaricare un documento con l'elenco dei prodotti scelti, completi di codici e finiture.

Il configuratore è accessibile liberamente dal sito Flaminia ed è consultabile da pc, smartphone e tablet.

Flaminia has always been a synonym of innovation in bathroom sector and now it continues to lead change with a dedicated tool for private customers, designers, and retailers: the bathroom configurator available online.

Designed to provide an engaging, intuitive, and customized experience, it allows users to furnish their own bathroom with Flaminia products in just a few clicks, combining them in real time to evaluate the overall effect. The system displays two separate views—one for the washbasin area and one for the sanitaryware—ensuring a complete and coherent vision of the environment. Navigation is guided step by step: at first you can select the collection, then the model and colour, and finally you can complete the composition with taps and accessories.

One of the most interesting new features is the simultaneous customization of the two main bathroom areas, but the real strong point is the possibility to view the result in augmented reality. After having configured the products, a smartphone is all you need to see your bathroom becoming reality directly in its own space, wherever you are. A useful and amazing feature that allows clients to choose being well informed, making each decision clearer and well thought. At the end of the process, a document can also be downloaded with the list of selected products, complete with codes and finishes.

The configurator is free on Flaminia website and it can be used from PC, smartphone, and tablet.



Scopri di più
Discover more





Le certificazioni Certifications



Il marchio **Italy^x** certifica l'italianità delle imprese sulla base del Disciplinare Tecnico, sviluppato da Il Sole 24 Ore ed è rilasciato alle aziende che producono esclusivamente in Italia. Questa certificazione, istituita in partnership con Confindustria, mira ad attribuire valore e dare visibilità alle imprese che incarnano e rappresentano i valori dell'italianità, sotto l'aspetto societario, produttivo e progettuale.

The **Italy^x** mark certifies the Italian nature of companies on the basis of the Technical Specifications, developed by Il Sole 24 Ore and it is issued to those companies that produce exclusively in Italy. This certification, created in partnership with Confindustria, aims to attribute value and give visibility to companies that embody and represent the values of Italianness, from a corporate, production and planning perspective.

Il SOLE 24 ORE

CONFININDUSTRIA



Certified Italian Excellence - ITALYX

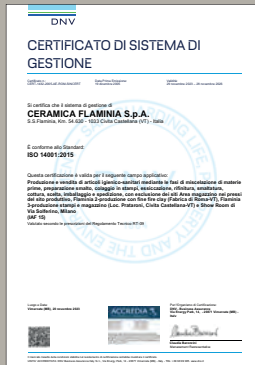

Environmental Management System
UNI EN ISO 14001

Quality Management System UNI EN ISO 9001



Energy Management System
UNI EN ISO 50001



Ceramics of Italy è il marchio che rappresenta l'industria ceramica italiana. La definizione "Made in Italy" non identifica solo una connotazione geografica, ma racchiude in sé i valori riconosciuti all'industria italiana in tutto il mondo: qualità, trasparenza, leadership nel design, innovazione, sostenibilità ambientale e responsabilità sociale. Il prestigioso marchio d'origine, ideato da Confindustria Ceramica, può essere apposto solo sui prodotti effettivamente realizzati in Italia.

Ceramics of Italy is the mark representing the Italian ceramic industry. The definition "Made in Italy" identifies not only a geographical connotation, but also embodies the values recognized to the Italian industry throughout the world: quality, transparency, leadership in design, innovation, environmental sustainability and social responsibility. The prestigious mark of origin, created by Confindustria Ceramica, can only be affixed to products actually made in Italy.

#ioscelgoresponsabile
#Ichooseresponsible

Scopri di più sulla sostenibilità
della Ceramica Italiana



La Ceramica Italiana. **Io scelgo la responsabilità.**

Italian Ceramics. **I choose responsibility.**



CONFINDUSTRIA CERAMICA

“  ”
Ceramics of Italy
for Sustainability

ceramica.info

Copyright
Flaminia 2026

Art direction
Giulio Cappellini



➔ FLAMINIA.

Spazio Flaminia Showroom

via Solferino, 18 - Milano

t. +39 02 89055303 **f.** +39 02 89055490

spazioflaminia@ceramicaflaminia.it

Ceramica Flaminia Spa

Via Flaminia km. 54,630 - Civita Castellana VT

t. +39 0761 542030 **f.** +39 0761 540069

ceramicaflaminia@ceramicaflaminia.it

2026

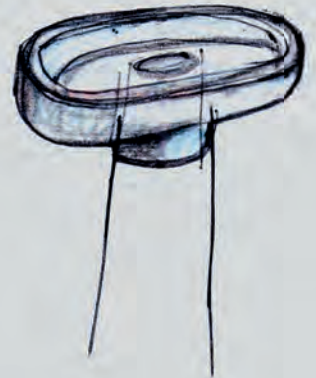
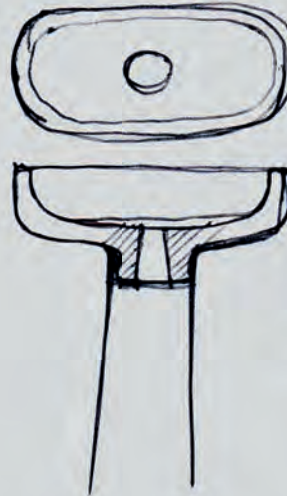

➔ **FLAMINIA.**