

2020

601803

OLI74 PLUS MECHANIC SANITARBLOCK S90

Preassembled structure for installation in front of masonry wall and finish in light wall and plasterboard wall (thickness reduced 90mm) with dualflush cistern (6/3 lt) suitable to wall hung wcs

INCLUDED:

- 1 Discharge pipe \varnothing 90 x 250
- 1 Seal for discharge pipe \varnothing 125
- 1 Connecting pipe \varnothing 45 x 180
- 1 Pan rubber seal \varnothing 45
- 1 Protective box
- 1 G 1/2" stop valve
- 1 Protection sponge for the stop valve
- 1 Flush bend \varnothing 90 / 90 L340
- 1 Adaptor \varnothing 90/110
- 1 Flush pipe \varnothing 56 x 165
- 1 Protection pipe \varnothing 90
- 1 Protection pipe \varnothing 45

COMPATIBLE WITH ALL FLAMINIA WALL-HUNG WC PANS

Package dim.

Weight 15 kg

Pz. Pallet n°

CE EN 14055 CL1

STRUCTURE:

- In painted tubular corrosion resistant
- Height regulation of the adjustable floor brackets (0-150 mm);
- Depth adjustable outlet bend
- Tested for 400kg load

CISTERN:

- Dual flush of 6/3 litres (adjustable to 4,5/3 - 4/2,6 - 4/2)
- Mechanic actuation
- Working pressure from 0,1 to 16 bar
- Resistance to atmospheric humidity (Hr < 90%).
- Polypropylene (PP) cistern highly resistant and inalterable to thermal stress
- Certified cistern according KIWA/SABS/SAI/WRAS/WSD/UPC standards
- Equipped with Azor Plus Inlet Valve, with delayed refilling (saves up to 9 litres of water per day) and silent according to the NF standard category Class I
- Supplied with anti-condensation lining
- "A" class for the Water Efficiency in compliance with the ANQIP Authority requirements

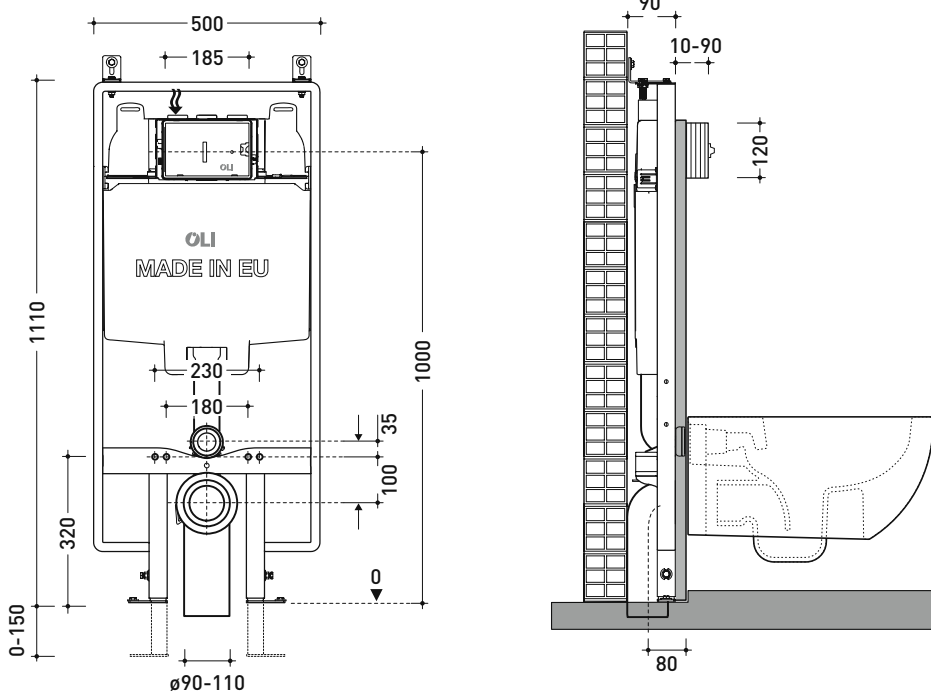

sizes in mm